

# COASTAL DEMOLITION POLICY AS APPLIED TO MODIFICATIONS OF OPENINGS

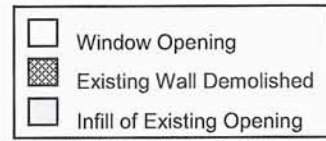

**DEMO POLICY:** When a window opening is increased horizontally (through demolition of at least one of the two king studs<sup>3</sup> and trim) to accommodate a modification of that opening, then the entire existing width of the opening to remain, plus any additional linear feet of wall demolished to modify the opening, is counted toward demolition. When a window opening is increased vertically (through demolition of the header<sup>1</sup> or sill<sup>2</sup>), but not horizontally, then no linear feet of demolition is counted.

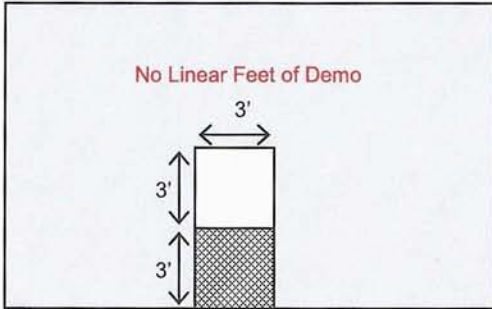

Sill (or header) of existing 3'x3' window is demolished to create a 3'x6' door does not result in demo

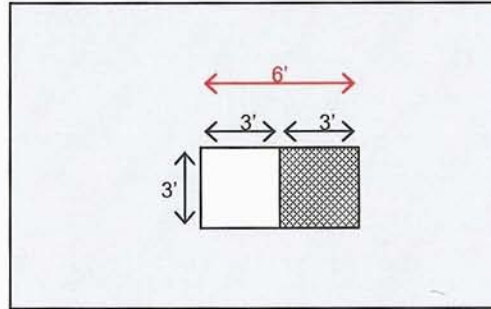

King stud & trim of existing 3'x3' window is demolished to create a 6'x3' window results in 6' of linear demo

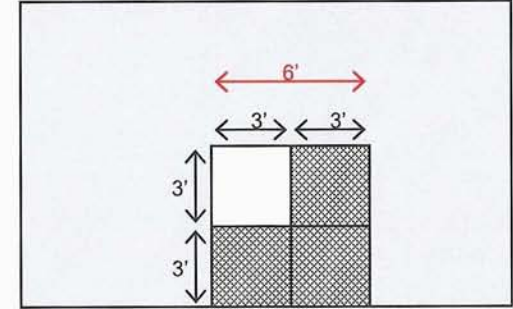

Sill & king stud & trim of existing 3'x3' window is demolished to create a 6'x6' opening results in 6' of linear demo

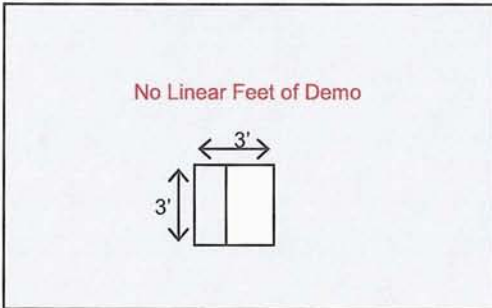

If an opening is framed in (either partially or completely) and the four planes of the window are left intact, then the entire width of the opening may be counted as remaining & not demolished.

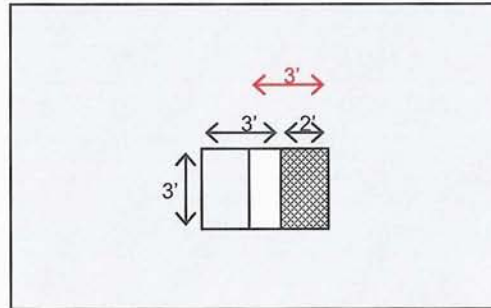

Shifting an existing 3'x3' window 2' to the side by framing in 2' of the existing opening and demolishing the king stud & trim plus 2 linear feet of wall results in 3' of linear demo

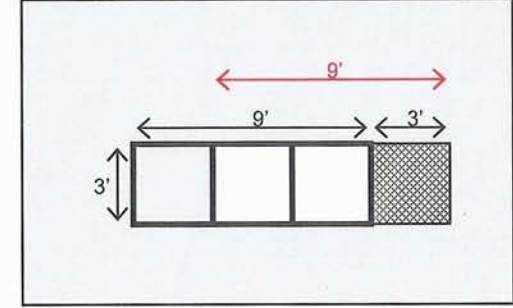

Shifting an existing 9'x3' multi-part window under a common header 3' to the side by framing in one of the existing windows and demolishing the outer king stud & trim plus 3 linear feet of wall results in 9' of linear demo

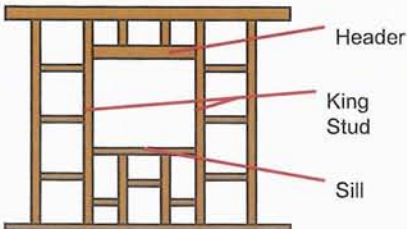

### Definitions:

<sup>1</sup>**Header:** A framing member that supports the cut ends of studs or joists, usually over a window or door.

<sup>2</sup>**Sill:** Another name for sill plate; the bottom horizontal framing member of a window or door opening.

<sup>3</sup>**King Stud:** The outer, full-height studs on either side of a window or door opening.

Page 3

# COASTAL DEMOLITION POLICY AS APPLIED TO OTHER WALL MODIFICATIONS

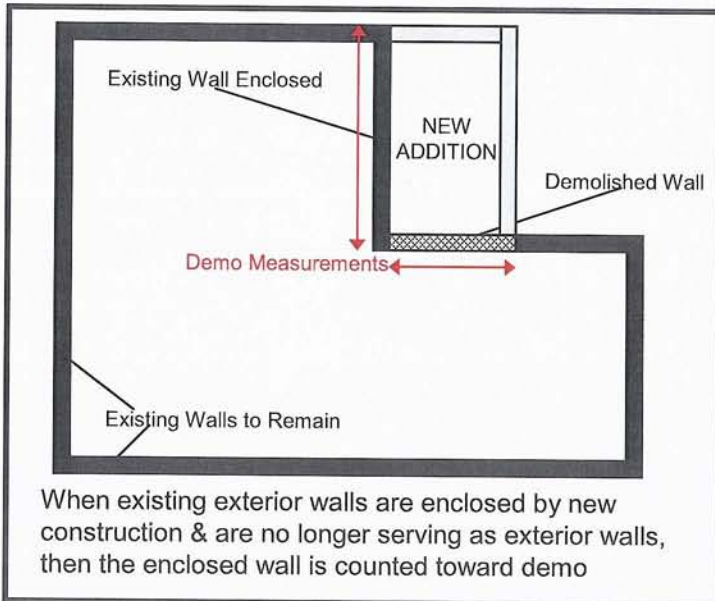
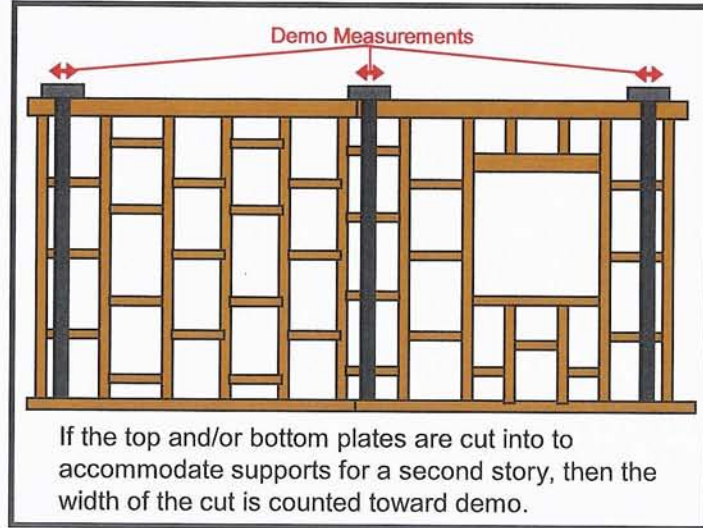
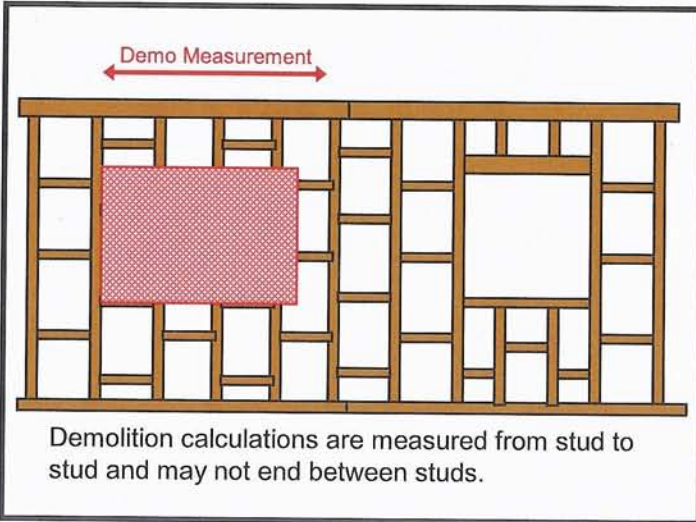

## PLEASE ALSO NOTE:



\* Walls to remain may not be shifted or moved in any way, even temporarily to accommodate foundation work or excavation. If the walls are shifted in any direction from their existing location, they are considered demolished for CDP exemption purposes. Walls must be suspended exactly in place for any foundation work or excavation activities.

\* Once a 50% exemption project has been finalized by the building inspector, the completed project becomes the "existing" walls, and another project proposing up to 50% demolition of those walls may be approved. The requirement that "existing walls" be in place on or before March 17, 1990 was removed with the adoption of the LDC in 2000.

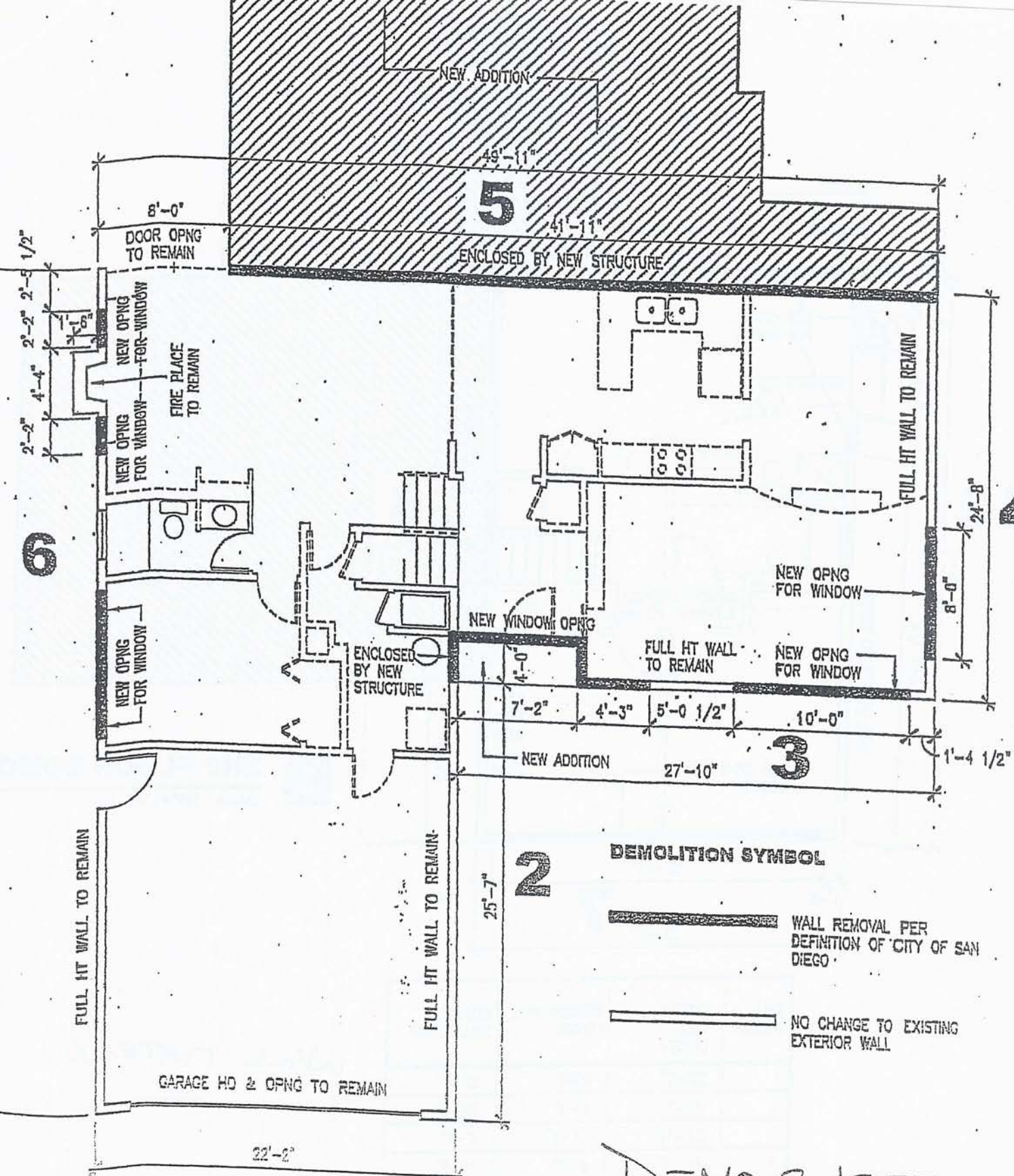

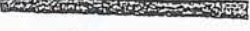

**DEMOLITION SYMBOL**

- 
 WALL REMOVAL PER DEFINITION OF CITY OF SAN DIEGO
- 
 NO CHANGE TO EXISTING EXTERIOR WALL

DEMO SHEET  
EXAMPLE



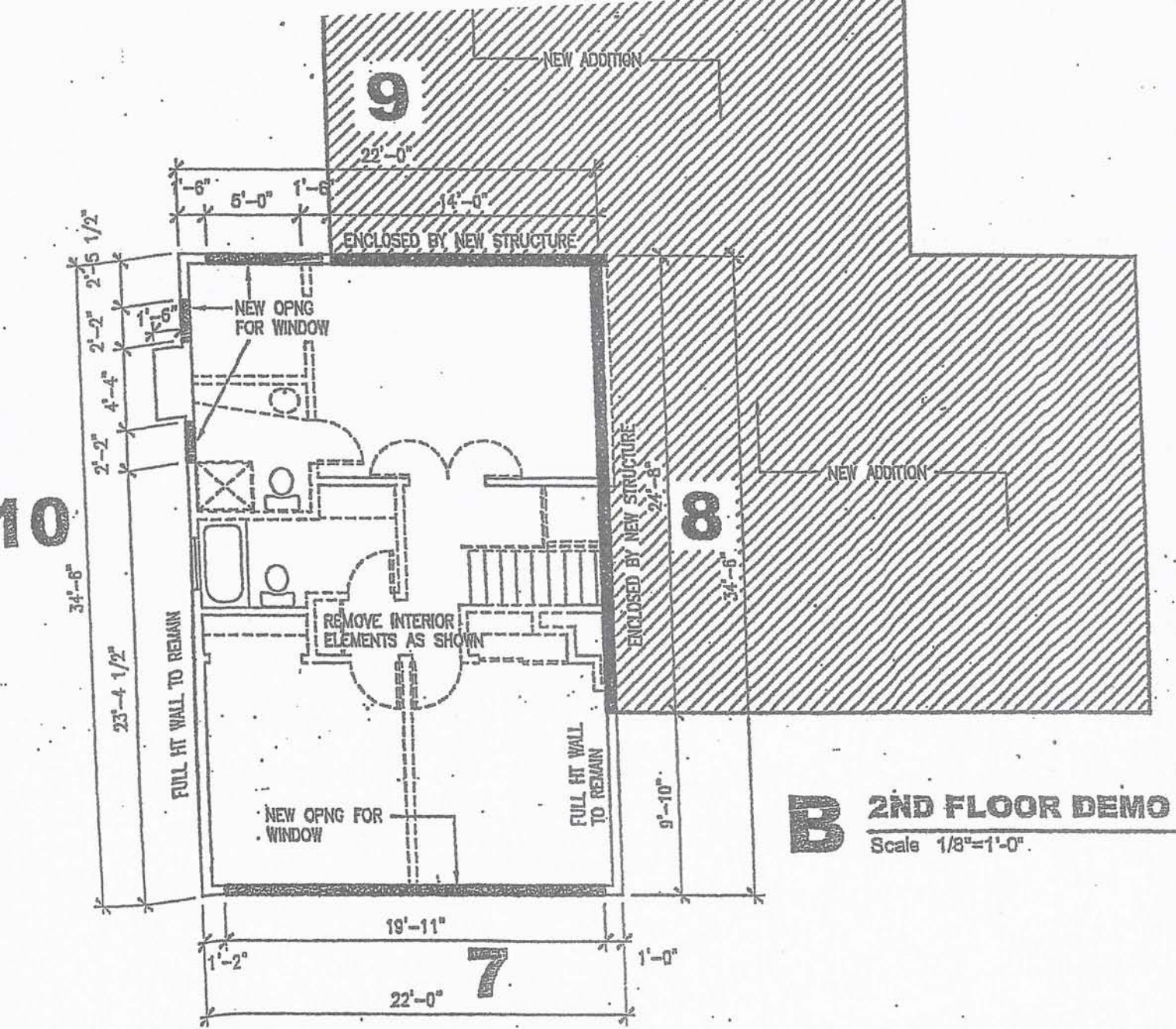

**B 2ND FLOOR DEMO**  
Scale 1/8"=1'-0"

WALL NUMBER	EXISTING WALL LENGTH	REMOVED WALL LENGTH	REMAINING WALL LENGTH
1	22'-2"	NONE	22'-2"
2	29'-7"	4'-0"	25'-7"
3	31'-10"	23'-5"	8'-5"
4	24'-6"	8'-0"	16'-6"
5	48'-11"	4'-11"	44'-0"
6	33'-3"	13'-4"	20'-11"
7	22'-0"	18'-11"	3'-11"
8	22'-2"	2'-2"	20'-0"
9	22'-0"	18'-5"	3'-7"
10	37'-5"	4'-5"	33'-0"
TOTAL	327'-7"	124'-9"	202'-8"

WALL MATRIX

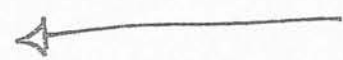

PROVIDE % TO REM

64% OF ORIGINAL WALL LENGTH TO REMAIN

Page 2